

March 2018

F O C U S

» **New to Range**

Our latest products

» **WSBK - Phillip Island**

Team Aruba.it Dominate in R1

» **S&S Update**

What's hot this month

» **Good Question!**

Q&A with our product experts

» **Engine of the Month**

Ford Ranger 2.5 WL / WL-T

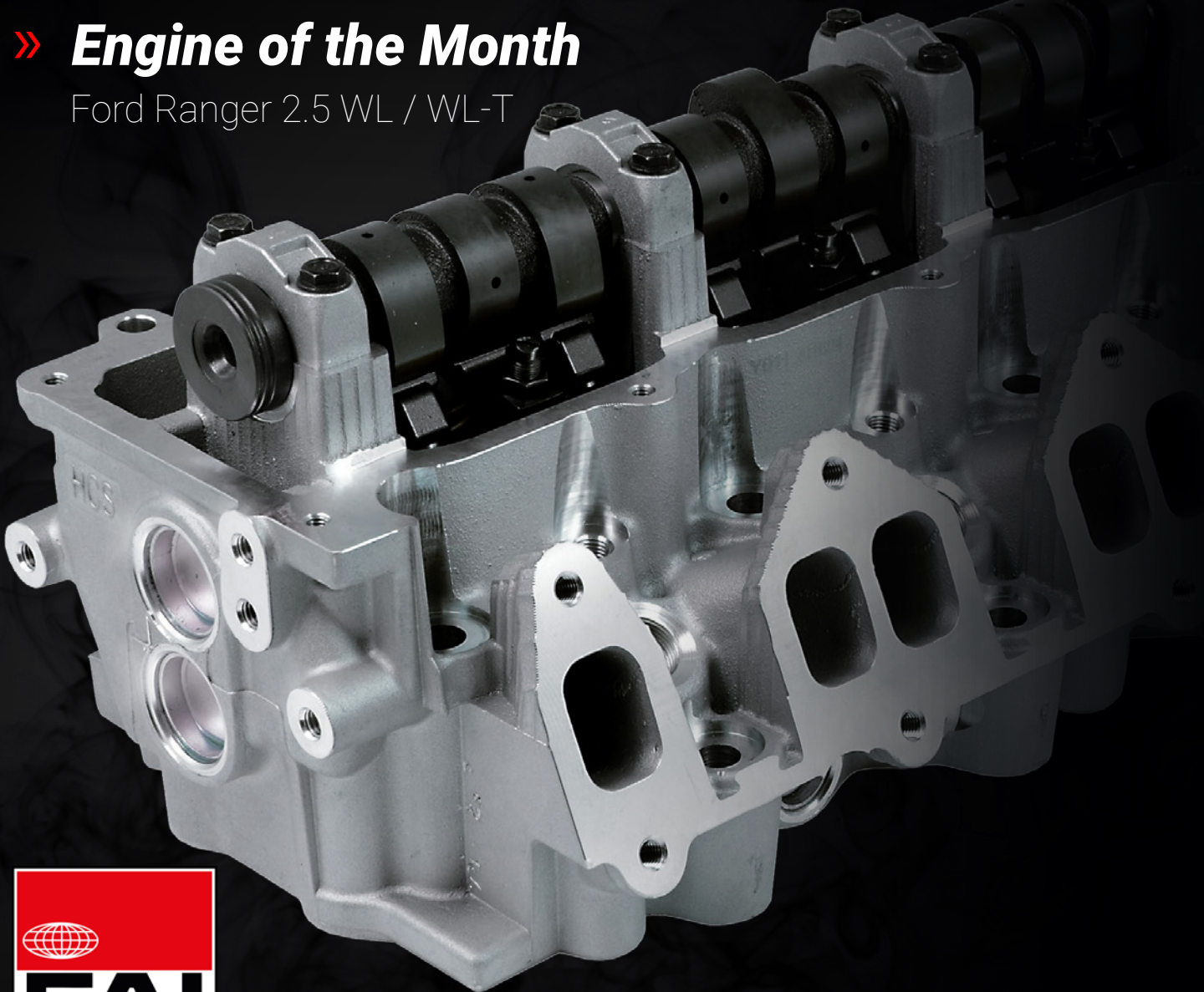

CN0003

faiauto.com



Oil Pumps

- ✓ Over 140 Parts in range
- ✓ 1400 Engine Variants Covered
- ✓ Meticulously Designed to OE Spec
- ✓ 50 New Part Numbers in our 2018 Catalogue
- ✓ Latest Technology
- ✓ Factory Tested & Quality Inspected



Best Availability. Best Value.
Best Quality. Best Service.

» Contents

» **World SBK Sponsorship**

Page 4 - 5

» **Vehicle of the Month**

Page 6 - 7

» **Steering & Suspension**

Page 8 - 9

» **New to Range TCK's**

Page 10 - 11

» **Good Question!**

Page 12 - 13

» **New to Range**

Page 14 - 15

» **Engine of the Month**

Page 16 - 17



» WSBK Phillip Island

Team Aruba.it Revved Up Over Double Win

» **Race 1:** After completing a morning practice and Superpole, the Panigale Riders were more than ready to tackle the first race of 2018, starting at 3pm local time.

Chaz started 5th on the grid and after some cat and mouse style riding, managed to make a strong comeback, securing a 3rd place podium position.

Marco managed to secure the lead by lap 17 and showing true grit, he defended 1st position until the checkered flag.

» **Race 2:** Marco Melandri, a veteran rider and the oldest contender on the line-up, had the closest win of his career with just

0.021 of a second between him and second place.

His 22nd win within the WSBK arena has propelled him into the history books as the most successful Italian competitor ever. Supported by a loyal fanbase especially by fellow countrymen, he's done us all proud.

Davies started the race in his usual style, quickly working his way up to 1st. After a quick pit stop & change of tyres he and Marco got back out there to take on the second half of the race when Chaz unfortunately crashed out on turn 9, lap 12.

Onlookers hearts sank when it was confirmed Chaz was out of the race, especially as it was looking like another Aruba.it dominated podium.

We'll have to wait a whole month before the excitement continues but rest assured we'll send a reminder and pre-race information for the second bout – Buriram, Thailand 23-25th March



**MELANDRI
ISLAND
CIRCUIT**





“ It’s been a crazy race... Towards the end, it was difficult to pass Rea under braking so I decided to focus on the final sprint and catch the slipstream out of the last corner, in which we were particularly fast, and the plan worked. I’m super happy and can’t wait to race at Buriram. ” **Marco Melandri**



“ Honestly, I felt great... Then, after we changed tyres, I still thought we could go for the win. I think it’s the first time I’ve ever pushed so hard on a completely new tyre, as we never leave the pits and go from zero to 100 percent like that, so maybe we took it just a bit too far and made a mistake even though it was quite late in the corner when I lost the front... We’ll regroup and be ready to fight at Buriram ” **Chaz Davies**



» **Vehicle of the Month**

Vauxhall / Opel Mokka 2012 onwards

When we first heard about the Vauxhall Mokka back in late 2011, our first thought was 'isn't that what I had from the coffee shop on my way in this morning?'

Despite an opinion dividing name, the Mokka has become a common sight throughout UK roads and beyond.

Launched in 2012, it struck a chord with parents, especially those with young children as the added height gave easy access to rear seats.

As you'd expect from a family SUV, the Mokka was never going to be fitted with a large power-plant, but instead a sensible choice of two diesel engines and two petrol engines,

including the 'have your cake and eat it' 1.4 T, which has plenty of pull but won't keep you going to the pumps too frequently.

The most efficient in the line up is the 1.6 CDTi, producing 136 BHP, however this has only been recently introduced, along with a mid-life facelift in 2016.

This low cost mini SUV has taken a large bite out of a saturated market and as a result we've seen a steady increase in demand and sales across our product ranges.

Listed opposite is a selection of FAI components in range, for a full overview and fitment specifications, please see the VOTM section at catalogue.faiauto.com or simply scan the QR code overleaf.

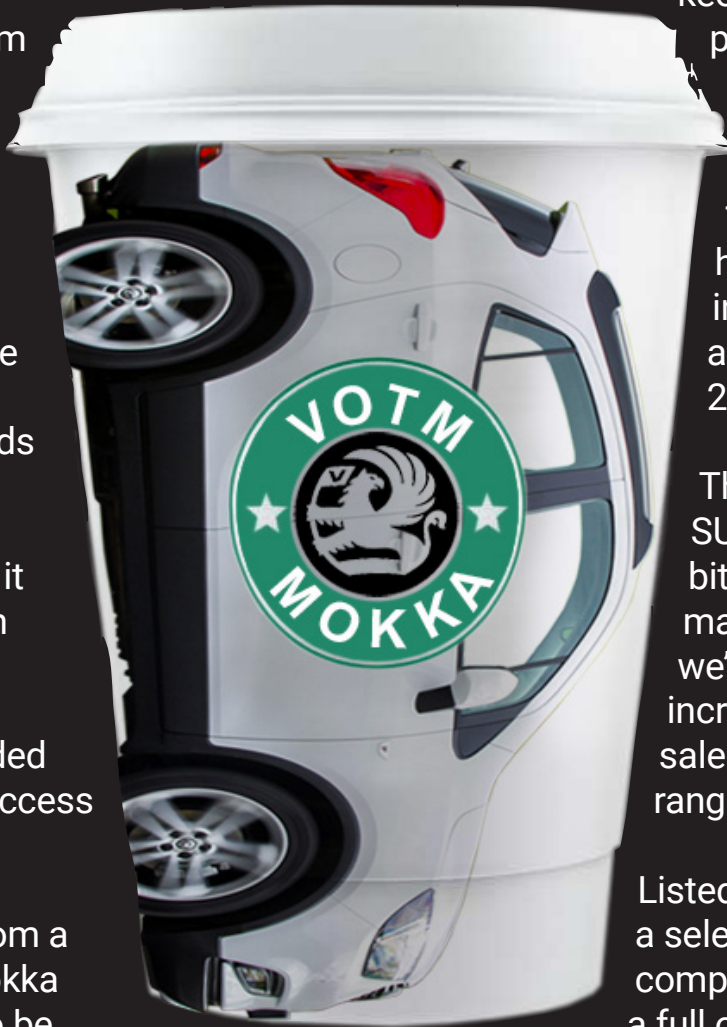

TCK98VVT

Timing Chain Kit



VC001

Valve Cover



TBK467

Timing Belt Kit



HS1443

Gasket Headset

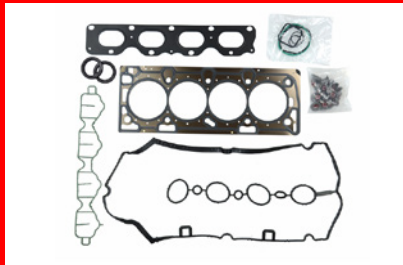

Did You Know?

The Vauxhall / Opel Mokka has sold over 700 thousand units since its launch (Europe)

WP6555

Water Pump



SS8078

Link Rod



C361 / C362

Camshaft



SS8855

Tie Rod End



SS9165 / SS9166

Control Arm



» Visit

[catalogue.faiauto.com/
vehicle-of-the-month](http://catalogue.faiauto.com/vehicle-of-the-month)



Log in to the FAI Web-Cat for a full shopping List.

OCV001

Oil Control Valve





Grip & Stability

When it matters most

FAI has continued to develop and increase its industry leading **OE spec** Steering and Suspension range through regular research and development. In the last 18 months, **over 1300 new part numbers** for some of the most modern vehicles have been added to range; all of which are **in stock and available to order**.

Whatever the terrain, trust FAI for **safe, assured handling and steering**.

Best Availability. Best Value.
Best Quality. Best Service.



» **Steering & Suspension**

Your monthly update

In the last 18 months, we have added over 1300 new references to our Steering and Suspension range. In the last month, we have added a number of new steering and suspension parts for some of the most modern vehicles on the road. Please consult our monthly new to range spreadsheet for full list.

» **New to Range Highlights**

SS9155 / SS9156

Wishbone



SS9336

Rack End



SS9307 / SS9308

Tie Rod End



SS9155 / SS9156	Wishbone LH/RH	Mini Countryman 2010-
SS9336	Rack end	Vauxhall / Opel Astra VII (K) 2015-
SS9307 / SS9308	Tie rod end LH/RH	Hyundai i20 (pb) 2008-
SS9026	Track control arm right	Range Rover Sport 2013-
SS9435	Front link rod	Jeep Wrangler II 02 - 07

» **Top Pareto Risers**

SS2799

Front Link Rod

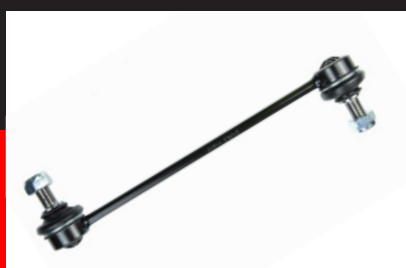

SS2465 / SS2466

Lower Ball Joint



SS2757 / SS2758

Tie Rod End

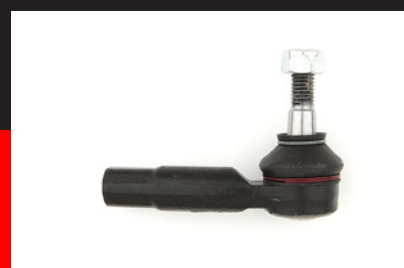

SS2799	Front link rod	Hyundai i30 2007 - 2016
SS2465 / SS2466	Lower ball joint	Audi A3 2006 - 2012
SS2780 / SS2781	Front link rod LH/RH	Nissan Qashqai 2007 - 2012
SS2925 / SS2926	Wishbone LH/RH	Nissan Qashqai 2007 - 2012
SS2757 / SS2758	Tie Rod End LH/RH	Ford Fiesta 2008-

» New to Range

Timing Chain Kits

We are market leaders in aftermarket Timing Chain Kits in both quality, size of range, exclusivity, technical expertise and the comprehensive nature of each kit. Below are some our latest featured kits to hit the shelf, available for purchase.

» TCK126VVT

AUDI	A3
SEAT	ALTEA, LEON, TOLEDO
SKODA	OCTAVIA II
VW	GOLF V, JETTA, PASSAT
2.0 FSI	05/2003 - 06/2010



» TCK42CRD-10



NISSAN	CABSTAR, MURANO II, NP300, PATHFINDER III/IV
2.5 dCi	01/2010 - Present

» VVT003 (in.) / VVT004 (ex.)

MERCEDES	C-CLASS W204 E-CLASS W212 SLK R172
1.8	2007 - 2014



Timing Chain Kits

& Oil Control Valves

- ✓ 430+ kits in range.
- ✓ Market leading range on vehicle parc.
- ✓ High quality, OE spec components.
- ✓ Each box sealed with an **Oil Specification Label**.
- ✓ Fully comprehensive kits. **One Job, One Kit.**
- ✓ More VVT applications than any other brand.
- ✓ Oil Control Valves manufactured in **Tier 1 OE facilities.**
- ✓ **Fully illustrated** 2017 catalogue.



Best Availability. Best Value.
Best Quality. Best Service.



» **Good question!**

Our product experts answer your questions.



Gary Hammond
Product Manager

Q: Do you sell the individual boots for ball joints?

A: We don't recommend the practice of replacing the boot alone as this can seal and hide

pre-existing damage, leading to the ball joint failure.

Once the boot has split, water and salt will have already started corroding the inner surfaces of the ball joint.



Once moisture and dirt are present, it creates a snow-ball effect, where the lubricant loses its correct operating properties, becoming a coarse paste; accelerating the rate of corrosion.

By replacing the ball joint in its entirety will ensure a safe, predictable ride and avoid excessive tyre wear.



Jake Barratt
Product Manager

Q: Should I recommend pre-lube to my customers when purchasing top end engine components?

A: When fitting engine components, especially cylinder heads, we recommend utilising our range of Torco MPZ Pre-Lube.

This popular product gives valve train surfaces a layer of protection at first engine start up, to avoid any metal-to-metal contact.



Failure to use pre-lube may result in damage to running surfaces, producing excessive heat, resulting in premature failure.

Part No. **AL-120Z**

Q: Should I recommend XT versions of SS2313 & SS2314 to my customer?

A: Our specially designed control arms (SS2313XT & SS2314XT) have an enlarged ball pin, heavy compound rubber and a high-performance grease which all contribute to its strength and longevity.

We recommend fitting these components to high mileage vehicles such as taxis that are exceeding 15,000+ miles annually. The highly durable XT variants are also suited to vehicles that operate on rough terrain or poor quality road surfaces to ensure a safe and reliable ride.



Did You Know?

FAI have an online 'Technical Centre' which contains all our fitment bulletins.

faiauto.com/technical-centre



Your questions and feedback help to fuel the information we create so please keep them coming!

enquiries@faiauto.com

» **New to Range**

Our latest products

» **BCH021**

CITROEN	RELAY
FIAT	DUCATO
FORD	TRANSIT
PEUGEOT	BOXER
2.2 HDi	2006 - 2014

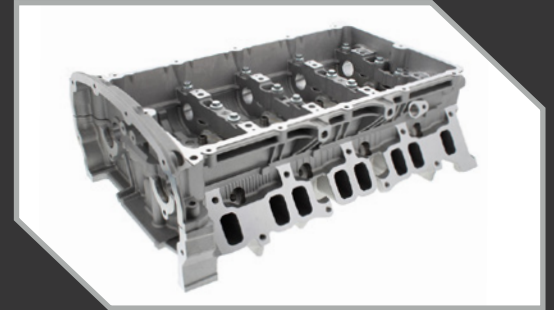

» **BFS174**



AUDI	A1, A3, A4, A5, A6A8, Q3, Q5, Q7
SEAT	ALTEA, EXEO, IBIZA IV, LEON
SKODA	FABIA II, OCTAVIA II & III
VW	GOLFVI & VII, PASSAT
1.6/2.0 TDi	07/2001 - 04/2007

» **WP6665**

BMW	3, 5 & 6 Series
M3, M5 & M6	2007 - 2013



» **HG1627**

**CITROEN
JAGUAR
LAND ROVER
PEUGEOT**

C5
F-PACE, XF, XJ
DISCOVERY IV
407

3.0 HDi

2009 - Present



» **WP6499**



MERCEDES

C-CLASS W203
CLK - C209
E - W211
SLK - R171

2.5 - 3.0

2005 - 2011

» **HS1742**

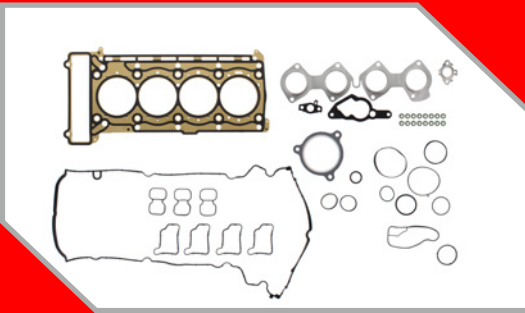

MERCEDES

C-CLASS W204
E - W212
SLK - R172

1.8

2007 - 2014

» **RC2239S**

NISSAN

MURANO II
NAVARA
PATHFINDER III

2.5 dCi

2005 - 2014

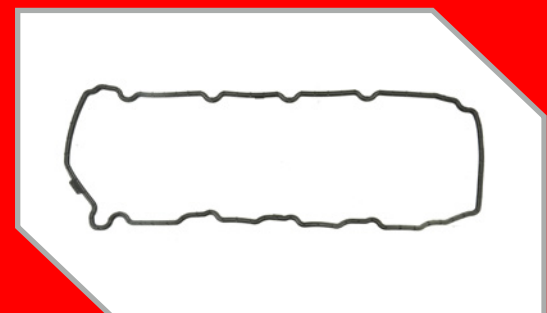

» *Engine of the Month*

Ford / Mazda 2.5 TD WL 12V

The Ford Ranger is used throughout the four corners of the globe, from the icy Road of Bones in far eastern Russia to the desolate dunes of the Sahara. Often modified to cope with specific conditions yet all started life as a Ranger, a name which has become synonymous with dependability.

Whichever incarnation of the Ranger you chose, the common denominator is that it's a work horse and as such has an extremely tough life, winching, towing and even pulling out the odd tree stump.

With all this hard work and as dependable as the Mazda derived 2.5 WL engine is, at some point it's going to need a little TLC... Okay, maybe a lot of TLC.

FAI produce a wide selection of engine components for the WL / WL-T including a complete, ready-to-fit cylinder head which will keep your customer happy and get them back to work as soon as possible.

Listed opposite is a selection of FAI components in range,

for a full overview and fitment specifications, please see the EOTM section at faiauto.com/engine-of-the-month or simply scan the QR code overleaf.

Did You Know?

Although the WL / WL-T is a Mazda engine, fitted to the B series, sales of the Ford derivative has out-stripped the Mazda by roughly 10 to 1. (UK)



C321

Camshaft



CCH014 / BCH014

Complete or Bare Head

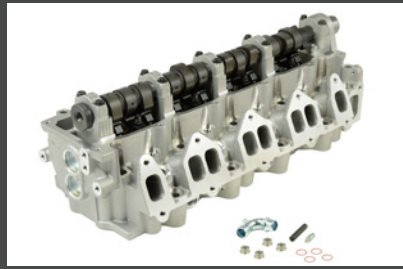

R166S

Rockers



3985000

Piston Kit



HS1804

Head Gasket Set

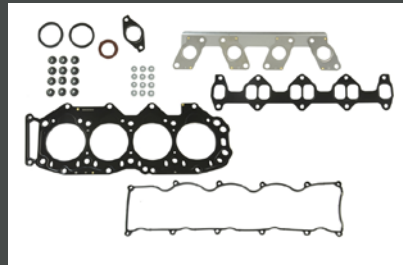

BFS319S

Followers



AN5268SA

Main Bearings Crank



KL4374LC

Big End Bearings



B1804

Cylinder Head Bolts

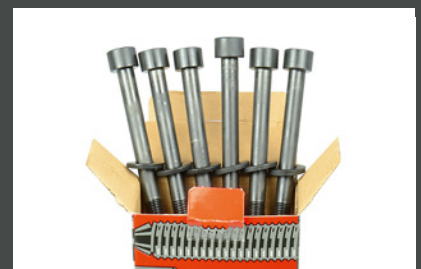

» **Visit**
[faiauto.com/
engine-of-the-month](http://faiauto.com/engine-of-the-month)



For the complete range for
this engine.

IV95104 / EV95105

In. / Ex. Valves



Oil Sump Pans

New to Range

- ✓ Manufactured to **OE** specification.
- ✓ **50 Part Numbers** in range.
- ✓ Leak and pressure tested.
- ✓ **Steel and aluminium** types in range.
- ✓ Includes **sump plug and gasket or silicone**.
- ✓ **Competitive pricing**.
- ✓ **First class cataloguing**.



**Best Availability. Best Value.
Best Quality. Best Service.**